



# MET ONE 6000P Series Remote Airborne Particle Counters

High performing, reliable 0.5 $\mu$ m sensitivity remote

# The MET ONE 6000P 0.5µm sensor remote airborne particle counter is the most reliable top performing, high sensitivity remote particle counter with a built-in pump.

## High performance

0.5µm sensitivity counter designed for ISO 21501 compliance for data accuracy and reliability.

## Easy to integrate with any FMS system

Communication options of serial, (RS232 or RS485), Ethernet only or Ethernet and Analog in dual communication mode (send data to two different locations at once).

## Faster trouble shooting and reduced downtime

Instrument can be diagnosed for flow, sensor, communication failures, and count alarm or count alert through built-in or external light stack.

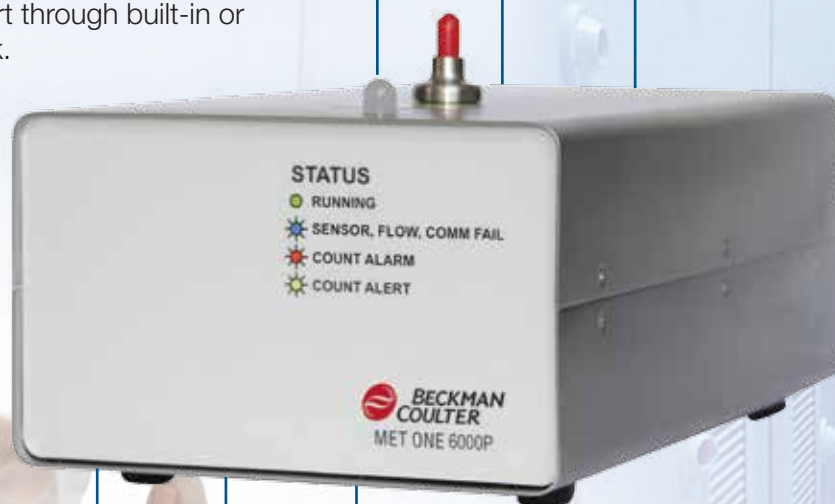

## Long Life Laser™ diode

Reduces the need for replacement parts and the overall cost of ownership.

## Built-in DP sensor controlled vacuum pump

Reduces initial installation cost and system infrastructure complexity. Install where ever you want without having to worry about access to an extensive vacuum system.

## Built-in flow sensor

Improves operational reliability during continuous monitoring.

**With an array of industry leading features and simplified installation options, the MET ONE 6000P is easy to integrate with any facility monitoring system.**

1 AC power input	6 Relative Humidity (RH) and temperature sensor port
2 Fuse Holder	7 Service port and optional light stack port
3 Exhaust fitting	8 4-20mA analog output; DC power input (DC version)
4 Calibration port (Service use only)	9 Ethernet Rj45 connector
5 Serial communication connector; DC power input (DC version)	10 DC power input (DC version)

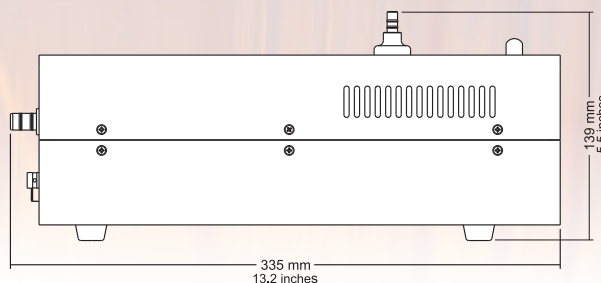
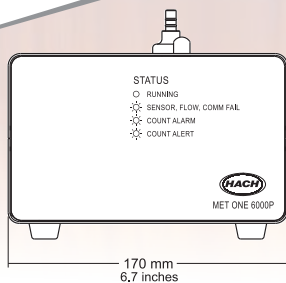
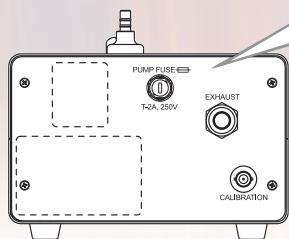
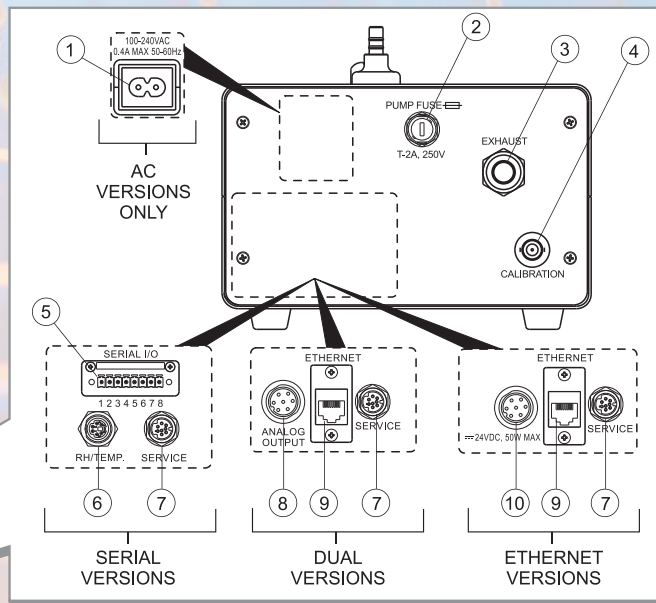

The MET ONE 6000P series remote airborne particle counter offers accurate and reliable continuous particle monitoring. With a sensitivity range of 0.5 to 10  $\mu\text{m}$ , the MET ONE 6000P series is designed to meet the specific needs of cleanroom operations within the pharmaceutical, semiconductor, hard disk drive and flat panel display industries.

With an array of industry leading features and simplified installation options, the MET ONE 6000P is easy to integrate with any facility monitoring system. These features also reduce downtime for instrument removal and reinstallation during routine calibration and preventative maintenance cycles. Built with Long Life Laser™ technology, the MET ONE 6000P offers enhanced diagnostic features that reduce troubleshooting time and related downtime costs.

New model for 2013 – 6015P with Serial communication (RS232-RS485) and integrated relative humidity and temperature port. This port enables the use of an optional probe that includes RH/Temp data along with the particle count data stream to further simplify installation and increase the information your monitoring system provides.



## Specifications

<i>Light Source</i>	Long Life Laser™ diode
<i>Weight</i>	4.62 kg (10.2 lb)
<i>Dimensions</i>	17.15 x 11.43 x 31.75 cm (6.75 x 4.5 x 12.5 inches)
<i>Enclosure</i>	304 Stainless Steel
<i>Status Indicator</i>	Multicolored LED for normal status, count alarm, count alert, sensor failure, flow failure or communication failure
<i>Power Requirements</i>	24 VDC ± 10% or 100 to 230 VAC 50/60 Hz (source: Class 2 limited energy, <150 VAC)
<i>Power Consumption</i>	50 W DC, 7.9 W AC maximum
<i>Operating Temperature</i>	10 to 32 °C (50 to 90 °F), 5 to 95% relative humidity, non-condensing
<i>Storage Temperature</i>	-40 to 70 °C (-40 to 158 °F), 5 to 98% relative humidity, non-condensing
<i>Signal Output Options</i>	Analog 4–20mA Ethernet with TCP/IP protocol Pulse Serial RS-232 Serial RS-485 with Modbus RTU or FXB communications protocol
<i>Pump Type</i>	Air Vacuum, rated for continuous use
<i>Number of Size Channels</i>	Standard 2 or Optional 4
<i>Flow Control</i>	Micro processor with Differential Pressure sensor
<i>Coincidence Loss</i>	All communication options except Pulse: 10% at 20,000,000 particles/m <sup>3</sup> (566,000/ft <sup>3</sup> )
<i>False Count Rate</i>	One or less in five minutes
<i>Accessories Included</i>	Isokinetic Probe, Purge Filter, Configuration Kit, Operator Manual
<i>How To Order</i>	2088615-PF-EA Ethernet only, AC Power 2088615-PF-ED Ethernet only, DC Power 2088615-PF-DA Dual (Ethernet & 4-20 mA), AC Power 2088615-PF-DD Dual (Ethernet & 4-20 mA), DC Power 2088615-PF-SA (Serial only), AC power 2088615-PF-SD (Serial only), DC power

Beckman Coulter Life Sciences  
250 S Kraemer Blvd  
Brea, CA 92821 USA  
Telephone: 800-866-7889  
E-mail: [insidesalesgp@beckman.com](mailto:insidesalesgp@beckman.com)  
[www.particle.com](http://www.particle.com)



CLASS 1 LASER PRODUCT

Contact manufacturer for complete compliance details



**Life Sciences**